

# Reusing and Rerating Older Rectifiers With New DC/DC Choppers

John Beak, Paul Buddingh, *Member, IEEE*, and Vince Scaini, *Member, IEEE*

**Abstract**—The recent development of high-power dc/dc converters (more commonly known as chopper rectifiers) allows customers the option to keep older rectifier transformers and refurbished systems if reconfiguring or installing new cell line loads. Normally, new cell line impedances would require the replacement of transformer/rectifier equipment. This paper is intended to describe how one can change the output operating range of existing equipment as well as increasing its output power rating with the use of chopper output sections. It will also discuss means of increasing output power without increasing existing transformer losses.

**Index Terms**—Chopper, harmonics, insulated gate bipolar transistor, power factor, rectifier, uprate.

## I. INTRODUCTION

AS DC-TO-DC converter systems (otherwise known as chopper-type supplies) gain acceptance for use as high-current dc sources, their application for retrofitting existing installations becomes a viable alternative to replacement of existing rectifiers. This retrofit need not be the complete replacement of transformer and rectifier. If the existing rectifier transformer is in reasonable condition, it can be reused as part of a complete chopper system. The retrofitting chopper may be in the form of a step-up boost chopper, for higher than originally specified output voltage, or of a step-down buck chopper for higher than specified rectifier currents. Issues to consider when reusing existing equipment will be the main topic of this paper.

## II. REASONS FOR CONSIDERING CHOPPER RETROFIT

If the existing rectifier transformer is deemed to be in good condition, or to be capable of being returned to good condition at a reasonable cost, there are the following two main reasons why it may be desirable to replace an existing rectifier with a chopper rectifier:

- 1) to increase the power available from the present transformer without reducing its life;

- 2) to enable a load of different impedance to be supplied by the same rectifier transformer within total kilowatt limitations.

If the existing diode or thyristor rectifier is in poor condition, it makes it easier to justify the investment in a chopper rectifier system. However, it may be worthwhile even if the existing rectifier is still in good condition, if the alternative is to replace the transformer to match new load requirements.

### A. Increasing Rectifier Transformer Power Capacity

At first glance, it may not appear reasonable to expect to increase the power (kilowatts) to the load without increasing the load on the rectifier transformer. However, it should be borne in mind that the limitation on load of a transformer is the temperature rise and the hot-spot temperature that has been decided upon to obtain acceptable life. Temperature rise is a function of the temperature differential required to dissipate a given amount of losses (kilowatts) and the actual losses generated in the transformer. Assuming that it is not feasible to increase the transformer's cooling capacity given the available cooling media, there are a number of ways that may be used to increase power output without increasing losses.

1) *Increase the Power Factor:* The power factor of the chopper itself is unity since both input and output are dc. It is fed by an unregulated diode rectifier, which has a power factor, depending on rectifier transformer and system impedance, in the range 0.925–0.95 for a 12-pulse system. A thyristor rectifier, by contrast, usually operates around 0.8–0.9 power factor and a diode rectifier with saturable reactors about 0.90.

2) *Increase the Voltage of the Secondary:* This could be done to a limited extent by operating the primary at a higher voltage. However, in most transformers increased iron losses would offset any reduction in copper loss if this increase were to be more than a few percent.

A more likely way to raise the secondary voltage is to use a lower ratio tap. This keeps the losses in the secondary the same for the same line current, while the increased voltage increases the available load kilowatts. In this case, the current in the primary does increase, but this is partially offset by the fact that less of the primary winding is used. The primary  $I^2R$  losses are about 40% of the total compared to 60% for the secondary in a typical rectifier transformer.

3) *Reduce the Harmonics in the Transformer:* The unregulated diode rectifier that feeds a chopper draws lower harmonic currents than a diode rectifier with saturable reactors and much lower than a thyristor rectifier operated at a typical firing angle (alpha) [1].

Paper PID 01–19, presented at the 2000 IEEE Petroleum and Chemical Industry Technical Conference, San Antonio, TX, September 10–14, and approved for publication in the IEEE TRANSACTIONS ON INDUSTRY APPLICATIONS by the Petroleum and Chemical Industry Committee of the IEEE Industry Applications Society. Manuscript submitted for review September 15, 2000 and released for publication May 16, 2001.

J. Beak and V. Scaini are with Inverpower Controls Ltd., Burlington, ON K9J 6M4 Canada (e-mail: jbeak@inverpower.com; vscaini@inverpower.com).

P. Buddingh is with Universal Dynamics Ltd., Richmond, BC V6V 2X8 Canada (e-mail: pbuddingh@udl.com).

Publisher Item Identifier S 0093-9994(01)06308-3.

TABLE I  
TYPICAL HARMONIC LOSS FACTORS FOR  
12-PULSE RECTIFIER TRANSFORMERS

Harmonic Number	Unregulated Chopper Diode Rectifier	Diode with 5% sat. react. Control	Thyristor with 15% phase control
1	100.0	100.0	100.0
3	0.3	0.3	0.3
5	0.3	1.8	1.9
7	0.3	1.5	1.6
9	0.1	0.1	0.1
11	2.9	6.0	7.2
13	1.8	4.2	5.5
15	0.0	0.0	0.0
17	0.2	0.3	0.6
19	0.2	0.2	0.5
23	0.6	0.4	1.2
25	0.5	0.5	0.7
29	0.1	0.2	0.0
31	0.1	0.2	0.1
35	0.3	0.6	0.4
37	0.2	0.5	0.5
41	0.1	0.1	0.2
43	0.1	0.0	0.2
47	0.1	0.1	0.4
49	0.1	0.2	0.3
Stray Loss Multiplier	1.22	1.88	2.41

The eddy-current losses in the transformer windings are increased by the “stray loss multiplier” given in Table I. This was calculated according to the formula

$$\text{Stray Loss Multiplier} = \sum_{N=1}^{50} (N^2 \cdot R^2) \quad (1)$$

where  $N$  is the harmonic number, and  $R$  is the ratio of harmonic current to fundamental.

Eddy-current losses at fundamental frequency in a typical rectifier transformer primary are about 15% of total  $I^2R$  losses. Fundamental frequency eddy-current losses in a sheet-wound secondary are typically 50% or more of total  $I^2R$  losses. On most rectifier transformers with a sheet-wound secondary, the secondary accounts for at least 60% of the  $I^2R$  losses at fundamental frequency. Eddy-current losses in a typical rectifier transformer are, therefore, at least 36% of total  $I^2R$  losses. It must be emphasized that these are typical numbers for a rectifier transformer with a sheet-wound secondary. These numbers can differ considerably between transformer designs.

From Table I, and using the ratios of the various types of losses in the foregoing typical transformer, the multiplier for total losses compared to the same rms current of pure sinusoidal fundamental frequency are shown in Table II. Note that the no-load losses are not considered in this table since they are not affected by harmonics or increased current.

It is evident that the reduced harmonics of the chopper system will enable the rectifier transformer to carry a higher current

TABLE II  
MULTIPLIER OF TOTAL  $I^2R$  LOSSES DUE TO HARMONICS

Rectifier Type	% Multiplier
Chopper with unregulated diode rectifier	1.08
Diode with 5% saturable reactor control	1.32
Thyristor rectifier with 15% phase control	1.51

without increasing the kilowatts of losses to be dissipated, thereby allowing the increase in the total system output power. However, the transformer manufacturer should be consulted on the hottest spot even if the temperature gradient improves significantly. Dissolved gas analysis will ensure that the unit performs properly with the modifications made.

4) *Increase the Utilization of the Secondary Winding:* Many rectifier transformers used double-wye secondaries and were connected to single-way rectifiers. Since this resulted in a more expensive transformer but a lower diode or thyristor count, this configuration was more often used on older units when the rectifier devices represented a higher proportion of total system cost.

Transformers originally built for use with mercury arc rectifiers were nearly always single way, even for quite high dc voltages.

It may be possible to separate the two wyes of a double-wye transformer secondary and connect each to an unregulated diode bridge rectifier. See Fig. 1. This gives a much higher dc voltage output, which can be transformed down to the voltage required for the load by the chopper. This results in a proportionately lower secondary current. The gain in this case is due to the fact that each secondary winding now has full wave ( $240^\circ$ ) current in it instead of half wave ( $120^\circ$ ). The rms value of two half-wave currents in two conductors is ( $\sqrt{2}$ ) higher than for the equivalent full-wave current in one conductor [2]. It is the rms current that determines  $I^2R$  losses. The rms current in the primary is not reduced in this case. However, in many rectifier transformers the conductor cross section of the primary is determined by fault withstand capability rather than continuous current capacity, so use may be made of the extra capacity gained from the secondary in this manner.

5) *Elimination of Interphase and Saturable Reactor Losses:* If interphases and/or saturable reactors can be removed from inside the transformer tank or deenergized as described in Sections V-A and V-B, the elimination of the kilowatt losses they would have generated will allow more of the available cooling capacity to be used to cool the main transformer core and coils. This may increase the load the transformer can carry without increasing the temperature rise.

### B. Change in Load Impedance

As load cell technology changes so does the load's impedance. In the case of membrane technology, generally, higher voltages are required. If the existing transformer consists of a double-wye secondary, the unregulated dc bus may be brought up to a voltage above the required output load voltage as described earlier. In this case, a step-down chopper supply would be used for the output regulation stage. The chopper would function analogous to a step-down autotransformer

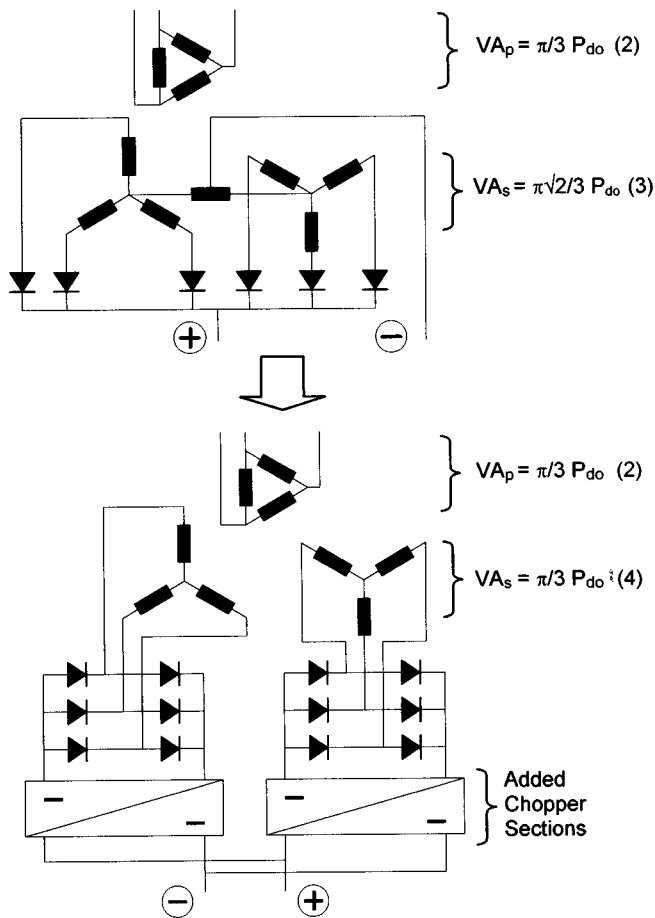

Where:  $P_{do}$  = DC Output including all voltage drops  
 $VA_p$  = Transformer primary rating  
 $VA_s$  = Transformer combined secondary rating

Fig. 1. Rectifier conversion.

where the product of input dc current and voltage would equal the output power.

In cases where the output voltage must be higher than what can be achieved by the secondary configuration a step-up chopper can be used. This method of regulation is typically not as energy efficient as the step-down method, but it can be a viable solution when an existing low-voltage rectifier has excess current capacity, but too low a voltage output for a higher voltage cell line that is to be installed.

### III. STEP-UP/STEP-DOWN CHOPPER COMPARISON

This type of dc-to-dc converter is referred to as a “chopper,” due to the nature of its operation [3], [4]. Both chopper circuits are composed of capacitor bank, a switching device [such as a transistor or insulated gate bipolar transistor (IGBT)], and a diode. The basic circuit diagrams of the two chopper-type circuits are outlined in Figs. 2 and 4, while associated waveforms are shown in Figs. 3 and 5, respectively. Additional auxiliary components generally required, such as snubber devices, are not shown in this diagram.

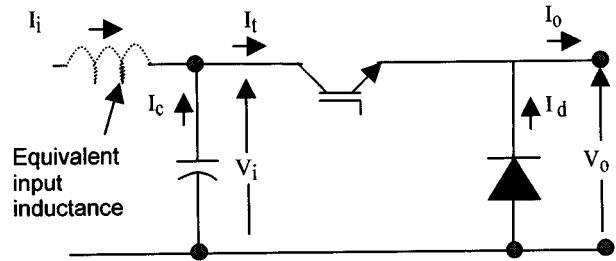

Fig. 2. Basic step-down (buck) chopper schematic.

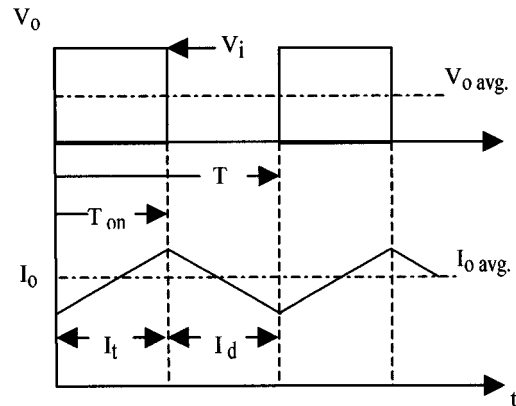

Fig. 3. Step-down (buck) chopper waveforms.

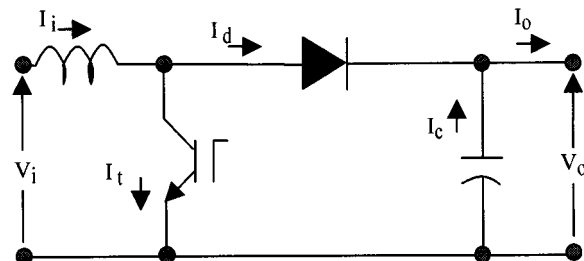

Fig. 4. Basic step-up (boost) chopper schematic.

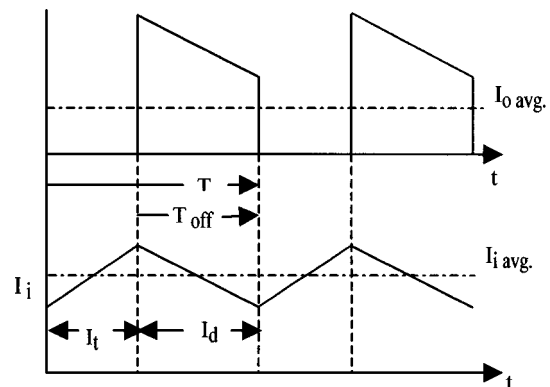

Fig. 5. Step-up (boost) chopper waveforms.

#### A. Step-Down (Buck) Chopper

The input dc feed to the chopper is pulsed to the load in a manner designed to reduce the output voltage. The percentage

*on time* or chopper duty determines the average output voltage. When the switching device (IGBT) is turned on, current from the bulk bus and the chopper dc capacitor flow to the load ( $I_t$ ). During the off state, current to the load must continue to flow since most loads are typically inductive. This current ( $I_d$ ) flows through the freewheeling diode. The load inductance also provides current smoothing, thereby limiting the output current ripple. This topology is ideal for high-current installations since the input rectifier and transformer secondary currents are reduced when compared to the output currents. This results in lower overall system losses.

If ideal circuit parameters for the step-down chopper are used (i.e., no-loss components) the following circuit equations can be used to describe the circuit voltages and currents:

$$V_o = \left( \frac{T_{\text{on}}}{T} \right) \times V_i \quad (5)$$

$$I_i = I_o \times \left( \frac{T_{\text{on}}}{T} \right) \quad (6)$$

where

- $T_{\text{on}}$  IGBT on time;
- $T_{\text{off}}$  IGBT off time;
- $T$  switching period;
- $V_o$  average output load voltage;
- $V_i$  average input bus voltage;
- $I_i$  average input bus current;
- $I_o$  average output load current.

### B. Step-Up (Boost) Chopper

The current from the input bus is pulled through the input inductance by the turning on of the shunting switching device ( $I_t$ ). During this interval, the blocking diode is reverse biased and the output capacitor supplies current to the load. When the shunting device is turned off, the current in the inductor continues to flow through the blocking diode ( $I_d$ ) to charge up the voltage on the output capacitor bank. The ratio of the switching period of the shunting switch to the off time determines the output voltage. This results in an output voltage that is higher than the input. To accomplish this, a higher input current than the output is required.

Similarly, if ideal circuit parameters for the step-up chopper are used (i.e., no-loss components) the following circuit equations can be used to describe the circuit voltages and currents:

$$V_o = \left( \frac{T}{T_{\text{off}}} \right) \times V_i \quad (7)$$

$$I_o = \left( \frac{T_{\text{off}}}{T} \right) \times I_i \quad (8)$$

## IV. REVIEWING SUITABILITY OF EXISTING TRANSFORMER AND RECTIFIER

To assure a successful conversion, several critical pieces of equipment must be checked for suitability. In addition to verifying the equipment's specification, present condition, and/or cost of refurbishing must also be assessed.

### A. Transformer

A particular prerequisite is the viability of the existing rectifier transformer(s). These costly items require a detailed analysis before proceeding with the project.

Maintenance records, including current and past dissolved gas analysis, are an excellent method of assessing the transformer's condition. An internal inspection by a qualified person can provide valuable information.

The transformer's specification is also very important. The suitability is largely dependent on the process requirements in terms of voltage and current. The tap for highest output voltage available will also have a great bearing on appropriateness of the transformer. Other current-carrying parts should be evaluated. Bushings, tap changers, leads, winding conductors, etc., should be reviewed for the new application. The reduced harmonics may have little impact on some of these, but increased current may.

Bear in mind that it may be possible to make major changes to the output current and voltage by using the transformer with a different rectifier configuration.

When contemplating extended transformer operation beyond nameplate rating or making changes to the transformer design, obtaining comprehensive design information and/or an evaluation by an experienced engineer is highly recommended. Bringing the transformer manufacturer into advisement is recommended since they may have some warranty or liability concerns with the modification of the use of the equipment.

### B. Rectifier

Using the existing rectifier for bulk dc conversion is another method of reusing existing equipment.

Again, this course of action is dependent on the general condition of the rectifier.

1) *Diode*: Use of an existing diode rectifier is an excellent application for reusing and rerating using a chopper. A diode rectifier without saturable reactor phase control would be ideal. If reactors are used, they must be configured to have a minimum effect on the system. If feasible, the reactors can be removed.

2) *Thyristor Rectifiers*: These can also be utilized for bulk power conversion by the ramping up of alpha control to zero. However, the condition of control electronics is of greater importance than with a diode rectifier, since precise firing control is required for reliable operation.

Furthermore, over years of service the makeup of fuses and thyristors often becomes a mix of various manufactures with unmatched characteristics. As well, the integrity of the fuses is reduced due to aging and the connections degrade due to varying assembly methods, relaxation of hardware, and possibly corrosion. As a result, thermal and current-sharing problems may arise. It is noted that equal current sharing is critical for continued operation of the thyristors. If one thyristor conducts much more than its rated current, it will eventually fail by overheating. As thyristors fail, the remainder are forced to share the load and additional thyristors are stressed, creating a cascade effect.

If the thyristor operation is unreliable, one possible solution is a conversion to diodes. The viability of this option is of course

dependent on the condition of the remaining power section components.

With older rectifiers, massive paralleling was a technological necessity and demanded careful matching of components. This made uniform load sharing inherently difficult to achieve and maintain over a long period. One solution utilized was the purposely designed bus and balancing reactor design. This would no longer be required since chopper sections could be connected to the output of each rectifier group with its own inner current loop and then paralleled on the chopper output.

3) *Other*: Very often, a major criterion for any upgrade is the available space for new equipment and the ease of matching to existing apparatus.

Auxiliary components of the rectifier, including the cabinets, heat exchangers, plumbing, and fans, must also be in satisfactory condition or be able to be economically replaced.

## V. REMOVAL OF NONESSENTIAL COMPONENTS

When a diode or thyristor rectifier is replaced by a chopper system, some of the components external to the rectifier may no longer be required. It is sometimes beneficial to remove these.

### A. Interphase Reactors

12-pulse diode and thyristor rectifiers usually use an interphase reactor to prevent current at  $6\times$  fundamental frequency from circulating due to the paralleling of two six-pulse groups that are  $30^\circ$  phase shifted relative to each other. The interphase is usually located in the transformer tank in the case of a single way configuration, but may also be located external in a bridge configuration.

Choppers control the current from each six-pulse group separately, so this interphase is not required if the transformer is to be used to supply diode rectifiers feeding dc to choppers. In addition, double-wye transformer secondaries have an interphase to limit circulation of current at  $3\times$  fundamental frequency in the neutral of each pair of wyes. These interphases are usually located in the transformer.

These interphases are still required if the transformer is to be used to supply a single-way diode rectifier feeding dc to choppers. However, if the configuration is changed so that the transformer supplies two diode bridge rectifiers, one from each wye, this interphase is no longer required.

If the interphases are not in the transformer, they can readily be eliminated when the rectifier is replaced. If they are inside the tank of a liquid-filled transformer, removing them may not be easy. The interphase between two six-pulse bridges is usually not in the transformer tank.

The interphase between two six-pulse single-way rectifiers, if there is one at all, is usually in the transformer tank. Since the choppers will equalize the currents in the two neutrals, there will not be a great deal of flux in the interphase so the iron loss will be low. However, there will still be copper loss in the conductors that form the (usually single turn) windings of the interphase. If it is physically and economically feasible, it is best to remove this interphase from the transformer and reroute the neutral bus.

If a transformer/rectifier is changed from double-wye single— way configuration to two bridges, each fed by one of the wyes, the neutrals of the two wyes have to be disconnected. In this case, the  $3\times$  fundamental frequency interphase is no longer energized, and there is no current in the bus through it. It does no harm to leave it in the transformer, as it contributes no losses.

### B. Saturable Reactors

Diode rectifiers usually contain saturable reactors. These act as a vernier adjustment between the steps of a load tap changer (LTC). They provide more rapid adjustment for current regulation, and allow the current to be equalized in two or more rectifier groups fed by the same regulator transformer. Saturable reactors have significant losses that increase with the amount they are able to reduce the dc output voltage. The need for saturable reactors is eliminated by the use of a chopper.

If the saturable reactors are located in the rectifier, or between the transformer and the rectifier, they will be automatically removed when the rectifier is replaced. If they are located inside the transformer tank, removing them may be much more costly. It is possible to remove much of their effect by fully saturating them with a continuous dc signal on their control winding. However, they still represent significant kilowatt losses, which is both an economic cost and a possible slight reduction in the maximum load that can be drawn from the transformer. In addition, the required power supply and the control winding itself are two unnecessary items that could fail and cause downtime. Careful consideration should be given to these factors in weighing the cost of removing saturable reactors from the transformer.

### C. Power-Factor Correction and Harmonic Filter Banks

An unregulated 12-pulse diode rectifier feeding choppers typically does not require harmonic filtering to meet IEEE 519 requirements [5]. It also does not require power-factor correction to meet many utility power factor contracts.

With existing systems, in some cases there may be no power-factor correction or harmonic filtering on the ac line, or there may only be power-factor correction banks. It is a significant advantage of substituting chopper rectifiers for existing thyristor rectifiers that it may remove the future requirement by the utility that harmonic filtering should be added, especially if demand load is to be increased. As well as having a substantial capital cost, harmonic filters need reevaluation and possible replacement or upgrading as the system changes. If the rectifiers being replaced are thyristors, and there are already harmonic filters on the bus, substituting choppers may allow the load to be increased without increasing filter and power-factor correction capacity.

## VI. INSTALLATION CONSIDERATIONS

In some cases, it is necessary to be concerned about the elapsed time the process will be shut down while the conversion is made as well as the cost of the design and physical work. In other cases, the process equipment is being rebuilt at the same time and this will be the critical path item in downtime.

### A. Cost of Installation

Major items in cost of installation are site and access route preparation, foundations, cable trenches, bus work, and piping, as well as the actual installation and commissioning of the new equipment.

If an additional transformer were needed to obtain the required kilowatts for the new load, costs for the preceding items would be greatly increased and there would be additional cost for high-voltage connections to the transformer and additional switchgear as well. This is part of the reason why so much emphasis is placed on accommodating any increased load requirements with the existing rectifier transformers.

All of the installation costs and downtime will be minimized if the new diode rectifiers and the choppers can be contained in a single enclosure with a similar footprint to the existing diode or thyristor rectifiers. As far as possible, the transformer throat, dc bus and piping entry points should also match the existing rectifiers.

It would also be ideal if all of the controls and cooling equipment were in the same enclosure as the rectifier and chopper, tested and shipped as a unit. If it is necessary to locate controls and external components of the cooling system at some distance because of confined space around the existing rectifiers, these should be provided with means of connection to the main unit that allow as much system pretest as possible and minimize site connection time.

### B. Time for Installation

If attention is paid to all of these considerations, and if the contractor applies sufficient resources, changeover and commissioning of a major electrochemical rectifier system in two to four weeks of elapsed time should be quite feasible.

## VII. WHEN TO INSTALL A NEW SYSTEM

### A. Poor Transformer Condition or Inability to Determine Mid to Long Term Dependability

Transformers with a poor history of operation, or a transformer without a maintenance history, should be suspect. Transformer testing will provide an indication of the condition. However, for liquid-filled transformers, dissolved gas is the best method of evaluating the insulation of a transformer. A rewind may be an option. However, the complex transformers often used are very expensive to rewind, and it may be less expensive to use a new transformer of a simpler design for the chopper system.

### B. Repeated Failures of Thyristors

When cascade failures are a regular occurrence and not easily resolved, using the existing system for bulk rectification may not be viable, due to ongoing costly repairs, not to mention the downtime required to complete the repairs.

### C. Others

To help optimize current sharing, rectifiers have been built with reactors for each diode/thyristor circuit. These reactors can be badly distorted due to the magnetic forces caused by repeated faults over the years. The momentary fault current that passes

through the circuit before the fuse clears creates enough force to deform the reactors, with resulting random inductance values.

With early rectifiers, massive paralleling of diode/thyristors (often in the hundreds of devices) can make replacement of reactors, diodes and fuses a very expensive venture, eliminating any savings of reusing existing equipment.

Wiring harness connection points can be severely corroded. Plating on devices can deteriorate and flake. Leaking low-voltage bushings can distribute a film of oil throughout the rectifier. Rectifiers with these types of problems are in generally poor condition, which precludes their reuse.

## VIII. CONCLUSION

The capability of a chopper rectifier system to operate at rated power over a range of load impedances enables the same rectifier transformer to be used for varying loads. The reduction of losses in the transformer allows the maximum load to be increased substantially compared to the same transformer feeding a thyristor rectifier. When replacing rectifier systems, this allows the use of existing rectifier transformers when these are in good condition or are capable of being rewound at much less than replacement cost.

## ACKNOWLEDGMENT

The authors wish to acknowledge S. Kennedy of Niagara Transformer, who provided the assistance and information for the generation of Tables I and II.

## REFERENCES

- [1] *IEEE Standard Practices and Requirements for Semiconductor Power Rectifier Transformers*, IEEE C57.18.10-1998.
- [2] *Power Converter Handbook*, GE Company Ltd., Peterborough, ON, Canada, 1976.
- [3] V. Scaini and B. M. Urban, "High Current DC Choppers and Their Operational Benefits," in *Conf. Rec. IEEE PCIC*, 1998, pp. 173-180.
- [4] K. C. Wu, *Pulse Width Modulated DC-DC Converters*. New York: Chapman & Hall, 1997.
- [5] *IEEE Recommended Practices and Requirements for Harmonic Control in Electric Power Systems*, IEEE 519-1992.
- [6] *Semiconductor Convertors; General Requirements and Line Commutated Convertors; Part 1-1, Specifications of Basic Requirements*, IEC 146-1-1, 1991.
- [7] *Semiconductor Convertors; General Requirements and Line Commutated Convertors; Part 1-2, Application Guide*, IEC 146-1-2, 1991.
- [8] *Semiconductor Convertors; General Requirements and Line Commutated Convertors; Part 1-3, Transformers and Reactors*, IEC 146-1-3, 1991.
- [9] *Semiconductor Convertors; Part 3, Semiconductor Direct D.C. Convertors (D.C. Chopper Convertors)*, IEC 146-3, 1977.
- [10] *IEEE Standard Practices and Requirements for Semiconductor Power Rectifiers*, ANSI/IEEE C34.2-1968.
- [11] *IEEE Guide for Loading Mineral-Oil-Immersed Transformers*, IEEE C57.91-1995.
- [12] P. Buddingh and J. St. Mars, "New life for old thyristor power rectifiers using contemporary digital control," in *Conf. Rec. IEEE PCIC*, 1999, pp. 177-183.
- [13] S. B. Dewan and A. Straughen, *Power Semiconductor Circuits*. New York: Wiley, 1975.
- [14] M. J. Fisher, *Power Electronics*. Boston, MA: PWS-Kent, 1991.
- [15] P. S. Maniscalco, V. Scaini, and W. E. VeerKamp, "Specifying DC chopper systems for electrochemical applications," in *Conf. Rec. IEEE PCIC*, 1999, pp. 161-169.
- [16] N. Mohan, T. M. Undeland, and W. P. Robbins, *Power Electronics: Converters, Applications and Design*. New York: Wiley, 1989.
- [17] M. H. Rashid, *Power Electronics*. Englewood Cliffs, NJ: Prentice-Hall, 1988.



**John Beak** received the B.Sc. degree in electrical engineering from Edinburgh University, Edinburgh, U.K., in 1963.

In 1965, he emigrated to Canada. He joined GE Canada, Peterborough, ON, Canada, where he held a number of technical and management positions until early 1999. Most of his technical career has been spent in power conversion products, but he has also had responsibility in various management roles for all types of switchgear. He later worked primarily in industrial rectifiers and, when GE sold their rectifier

business, he took a position with Inverpower Controls Ltd., Peterborough, ON, Canada, in sales, marketing, and application engineering for rectifiers, including dc choppers, and various other products. In this position, he is a key member of Inverpower's Sales and Marketing Team.

Mr. Beak is a Registered Member of the Professional Engineers of Ontario, Canada.



**Paul Buddingh** (S'89–M'90) received the B.Eng. degree in electrical engineering from Lakehead University, Thunder Bay, ON, Canada.

Following graduation, he spent several years working out of Toronto, ON, Canada, as an Electrical Consulting Engineer working in heavy industry, primarily in the electrochemical field. In 1991, he cofounded Mirus International, where he applied a new magnetic approach to solving zero-sequence harmonic problems in low-voltage systems. In 1997, he joined Universal Dynamics Ltd., Richmond, BC,

Canada, where his work is centered around designing high-reliability power systems, power conversion issues, and resolving power system problems for a number of industrial clients.

Mr. Buddingh has authored two papers for the Petroleum and Chemical Industry Committee of the IEEE Industry Applications Society. He is a Registered Engineer in the Provinces of Ontario and British Columbia, Canada.



**Vince Scaini** (M'98) received the B.A.Sc. degree in electrical engineering from the University of Toronto, Toronto, ON, Canada, in 1979.

He spent three years as a Research Associate at the University of Toronto and with Inco Research, Birmingham, U.K., working in the fields of electrometallurgy and power electronics. In 1982, he joined Inverpower Controls Ltd., Burlington, ON, Canada, where he has been involved in various engineering and management roles, including the startup of original manufacturing facilities, design of converters for numerous

power applications, and implementation of a quality control program. In his current role as Manager of Application Engineering and Proposals, he is a key member of the Sales and Service Team.

Mr. Scaini has authored three papers for the Petroleum and Chemical Industry Committee of the IEEE Industry Applications Society and is a member of the IEEE Power Electronics Society. He is a Registered Member of the Professional Engineers of Ontario, Canada.